

# Clamps for boxed goods

**UKK**

Clamps type **UKK** are used for palletless transport of packaged goods.

## Carton clamp UKKS

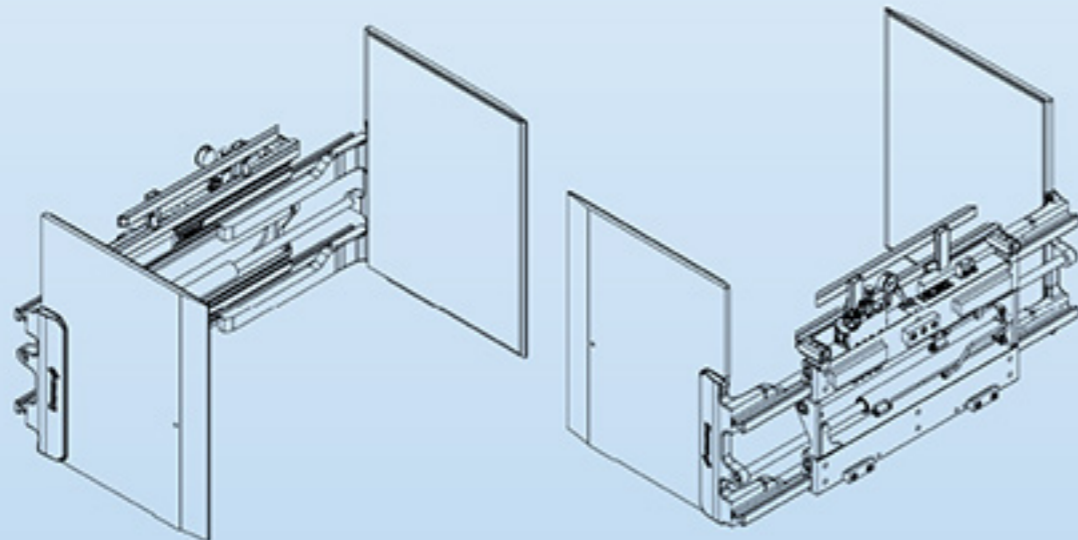

The UKKS type is a carton clamp with rigid arms. The clamping arms consist of slim carrier plates which are coated with rubber. The compact design allows for narrow standing goods to be clamped.

## Appliance clamp UKKSE

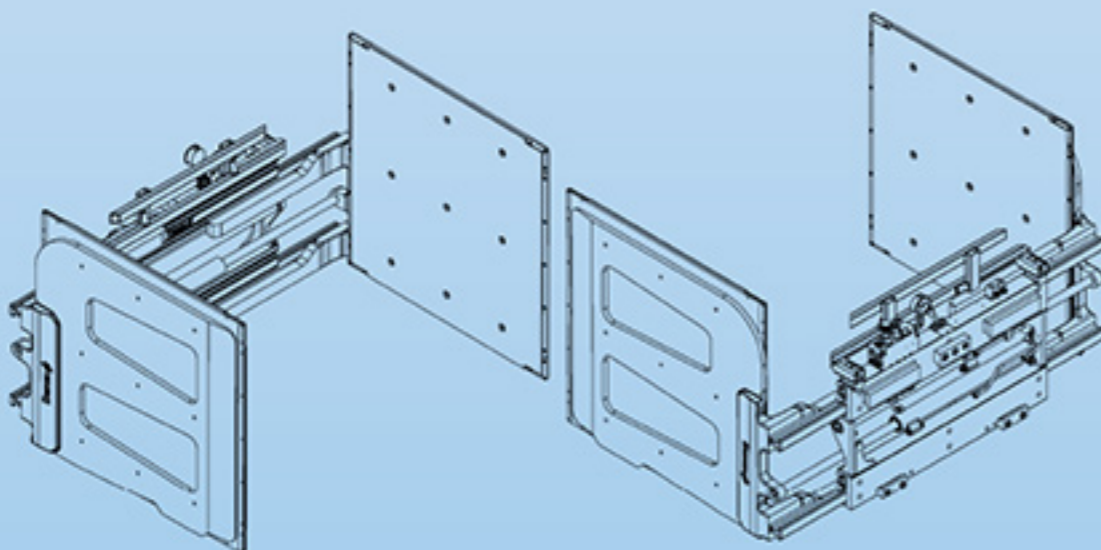

The UKKSE type is an extension of the rigid arms. The arms are additionally equipped with a bolt-on aluminium plate. This has the advantage that the clamp can adapt to the goods. The inclination of the gripping surface can be varied by using adjusting washers, thus helping to achieve a better force distribution for sensitive goods.

## Appliance clamp UKK-PE

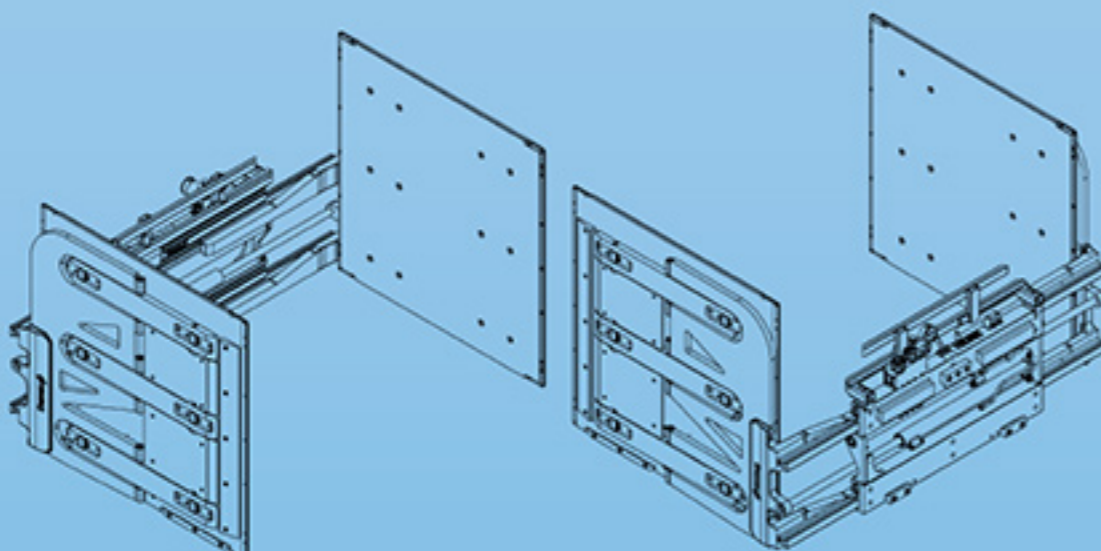

The PE type are appliance clamps with single articulation arms. The contact plate is movably mounted. This design principle offers considerable advantages with regard to the distribution of the clamp force over the entire contact surface. The plate articulation distributes the force from front to rear. This prevents local overloading of the goods while still ensuring secure gripping. This clamp is ideal for electrical appliances to be handled. In addition, this class offers a multitude of options. The device can be adapted to a wide variety of applications. The clamping arms themselves can be optimally adjusted to the transported goods. If different goods require different clamping forces, the UKK-PE can be easily extended with different pressure selection valves as an option.

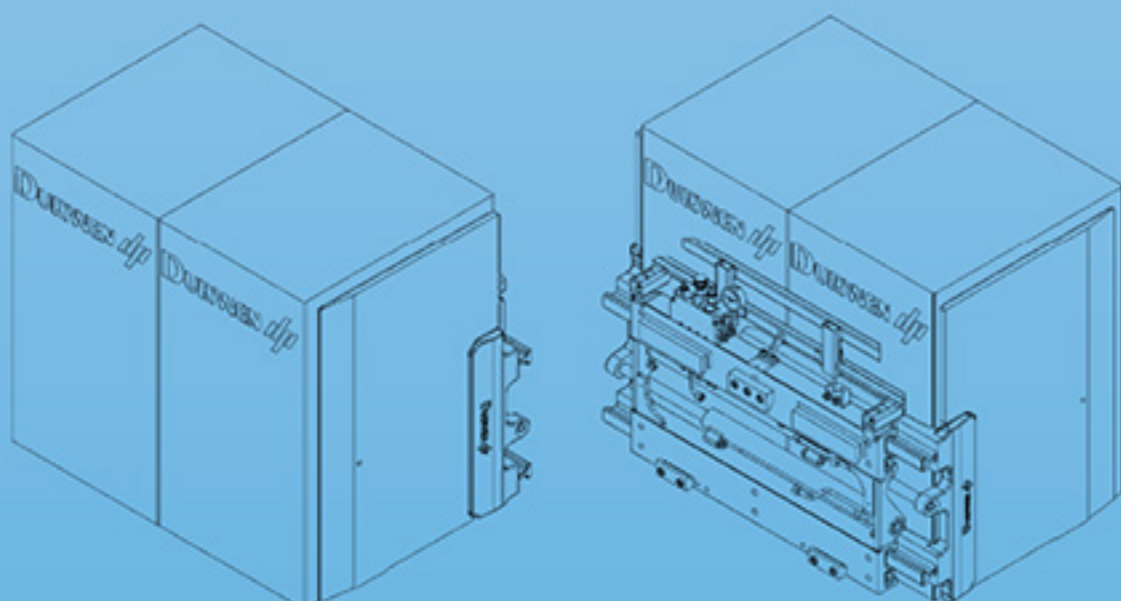

**DURWEN**  
Forklift Attachments



More than 70 years experience



# Clamps for boxed goods

## surface coatings

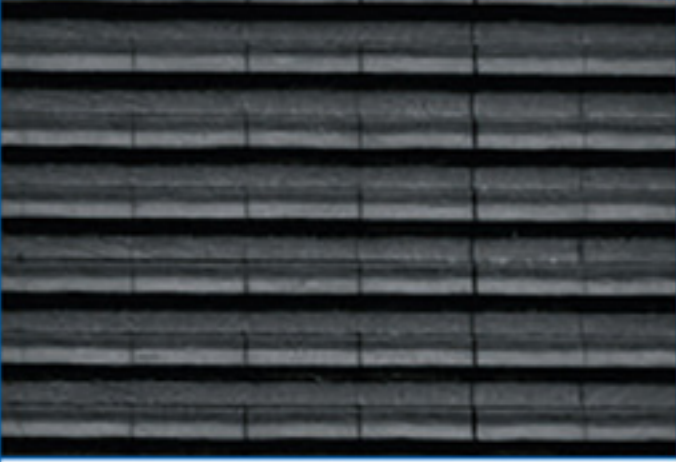
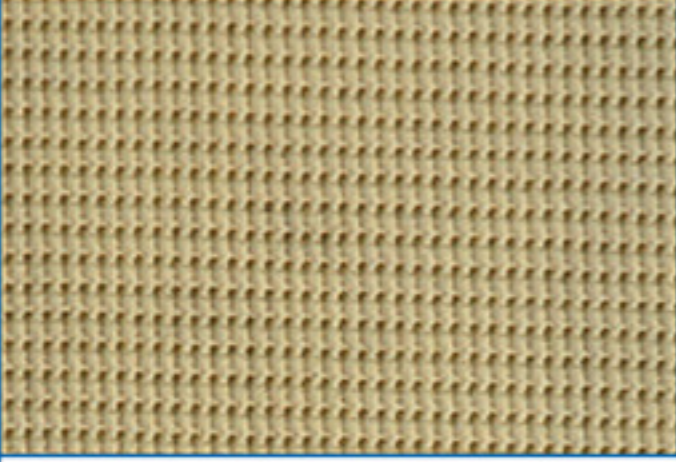
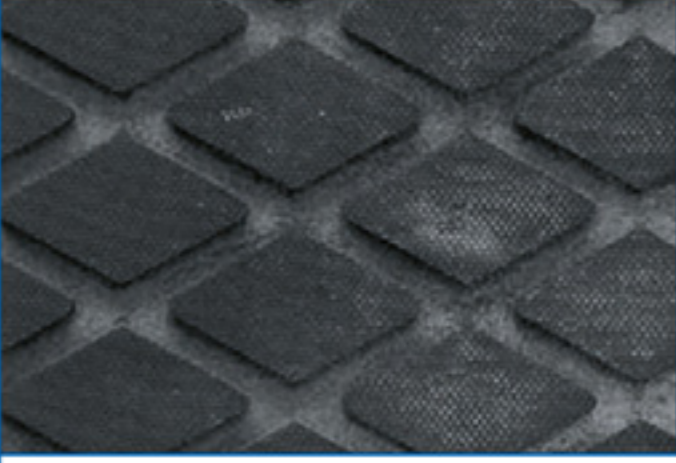
**UKK**

	supergrip black standard on Durwen clamps approx. 65 shore	<ul style="list-style-type: none"><li>• multi-purpose rubber</li><li>• excellent friction</li></ul>
	grooved rubber black approx. 65 shore	<ul style="list-style-type: none"><li>• multi-purpose rubber</li><li>• improved grip</li><li>• good durability</li></ul> <p>upon request</p>
	supergrip beige approx. 45 shore	<ul style="list-style-type: none"><li>• excellent friction</li><li>• non-marking</li><li>• less hardness</li></ul> <p>upon request</p>
	rhombic rubber black approx. 65 shore	<ul style="list-style-type: none"><li>• good durability</li><li>• excellent friction</li></ul> <p>upon request</p>
	rhombic rubber white approx. 60 shore	<ul style="list-style-type: none"><li>• excellent friction</li><li>• non-marking</li><li>• less hardness</li></ul> <p>upon request</p>
	smooth rubber black approx. 65 shore	<ul style="list-style-type: none"><li>• excellent friction</li><li>• good durability</li></ul> <p>upon request</p>

other surface coatings upon request



# Clamps for boxed goods

**UKK**

## Appliance clamp UKK-PD

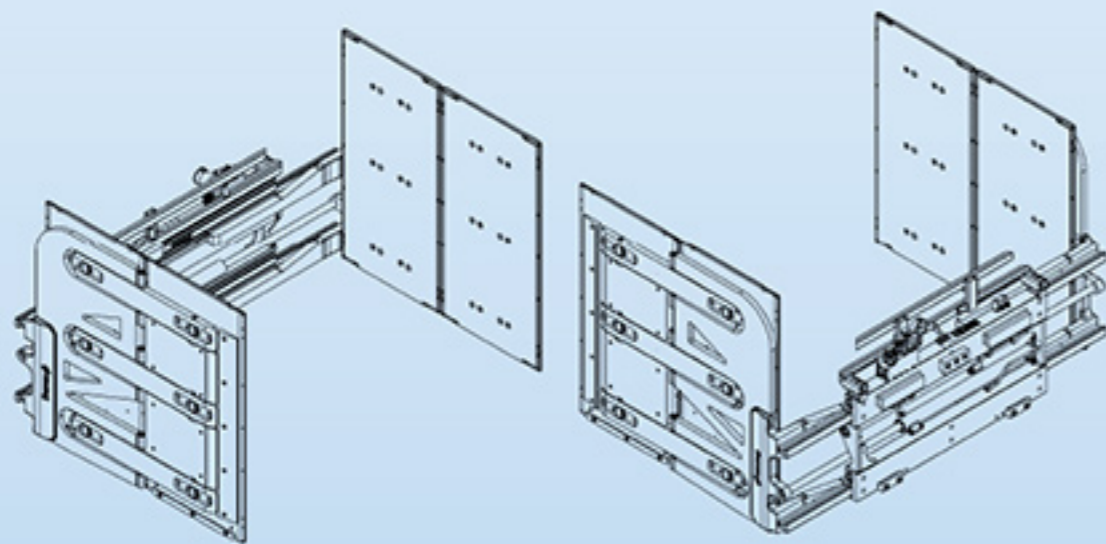

The PD type is an appliance clamp with double oscillating arms. The gripping surface is additionally separated in the middle, resulting in a front and a rear partial surface. Each of these sections can also move around the vertical axis. The force is optimally distributed to the individual rows and evenly applied to the row itself. The clamp arm offers the best possible adaptation to the transported goods and thus helps to reduce the loads on the goods and to eliminate damage to the packaging as far as possible.

## Appliance clamps UKK-PSE / UKK-PSD

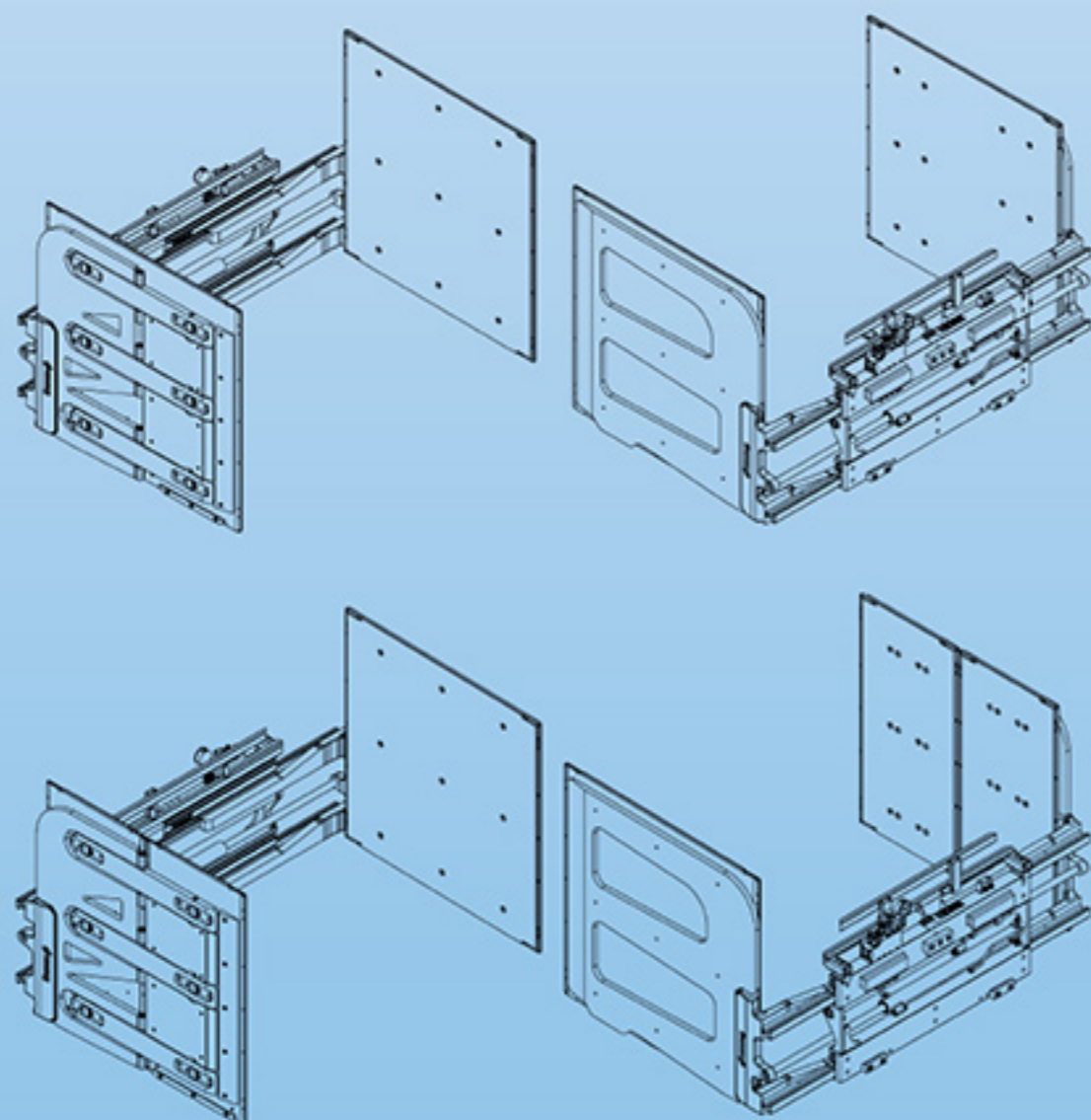

The PSE and PSD types are a combination of rigid and oscillating arms. This combines the advantages of a rigid arm with aluminium plate and the advantages of a pendulum arm. These units cannot achieve the even force distribution of a UKK-PE but run more easily into densely stacked goods.

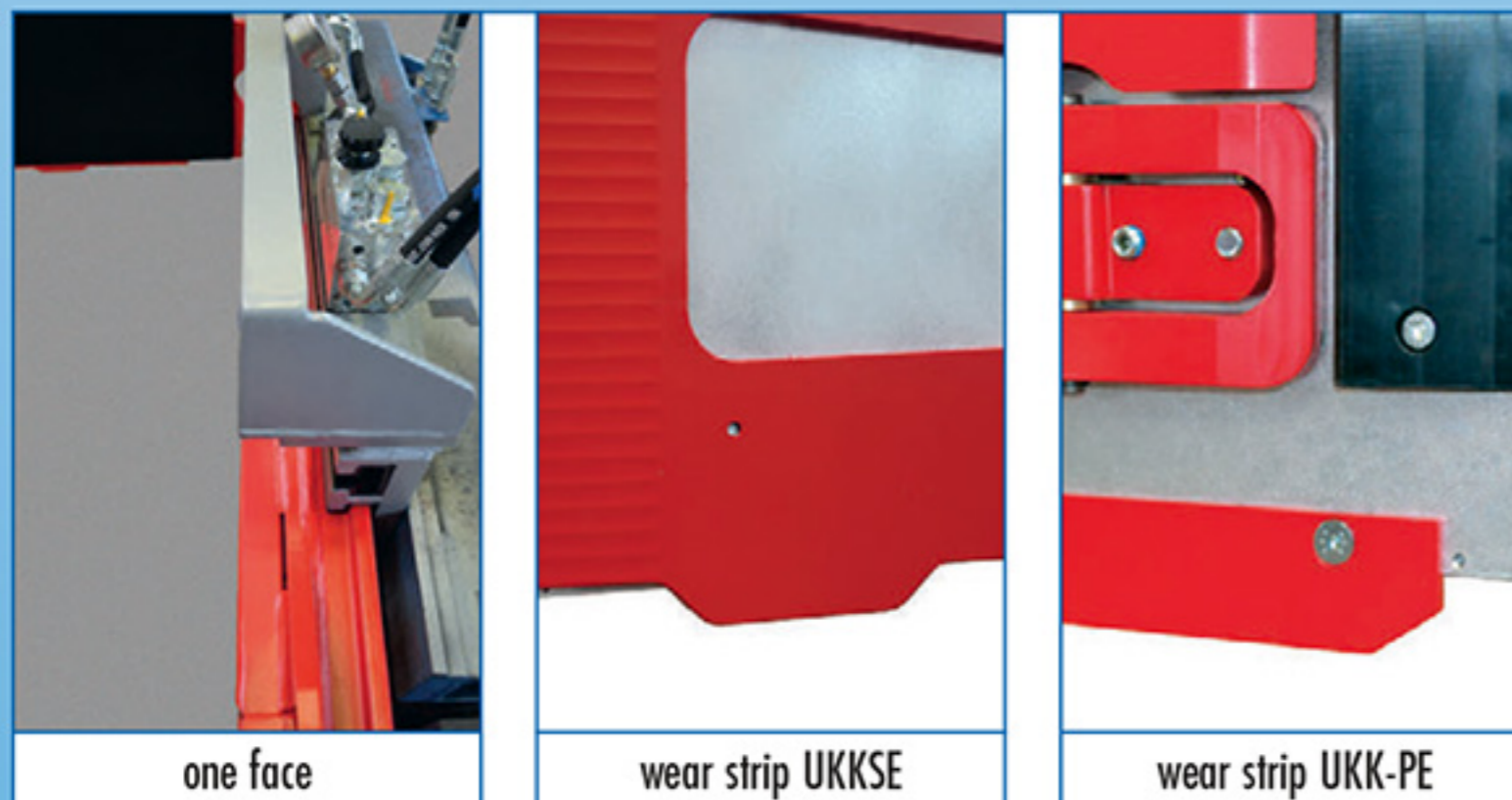
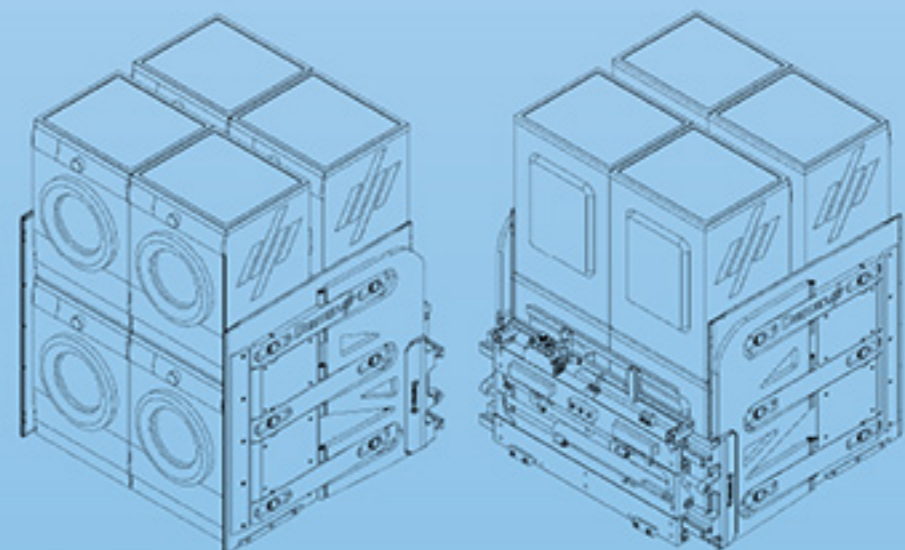

one face

wear strip UKKSE

wear strip UKK-PE

**DURWEN**  
Forklift Attachments

More than 70 years experience



# Carton clamp, rigid arms

**UKKS**

integral sideshift

The **carton clamp UKKS** with rigid arms is designed for the loading/unloading of well packed goods without pallets. The slim arm design allows for easy picking of dense standing goods.

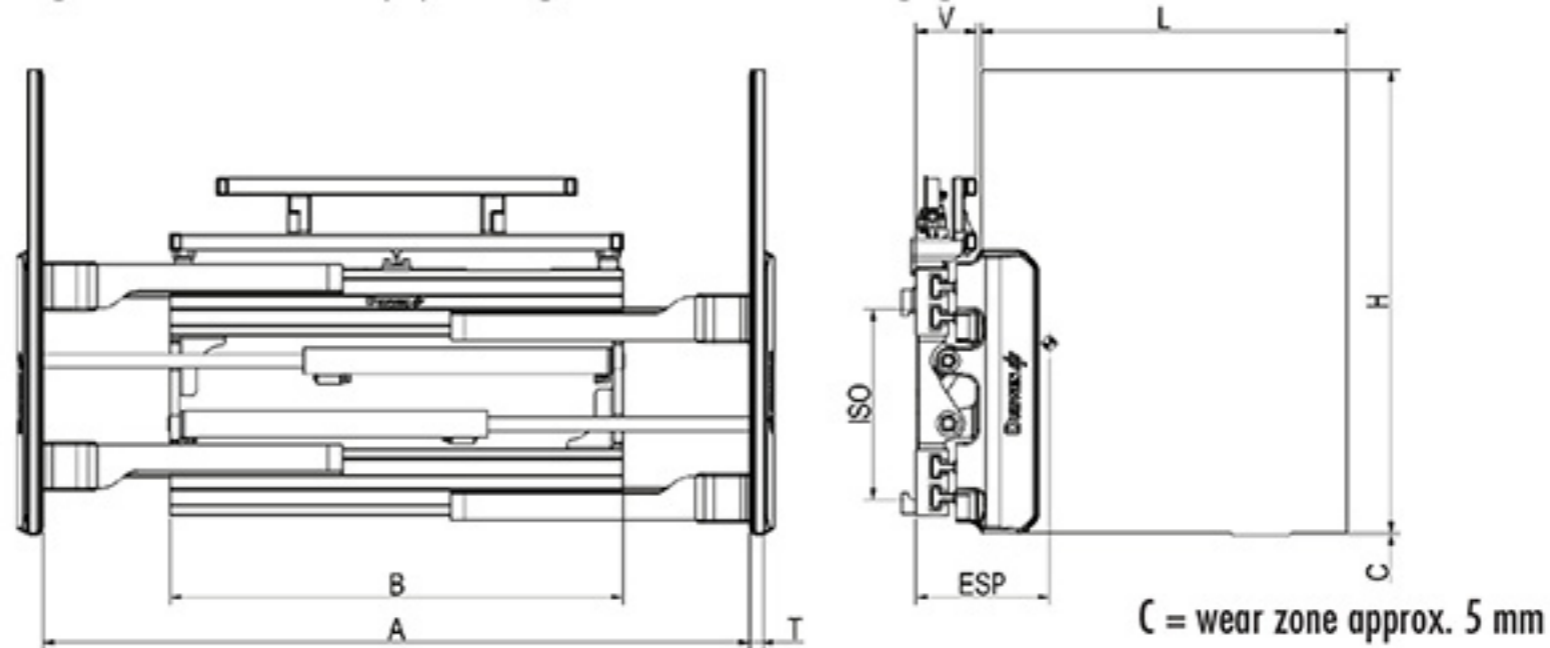

type	capacity kg LC mm	lift truck to LC mm	ISO	B mm	A ITI mm	arm length L mm	arm height H mm	arm thickness T mm	V LLC mm	ESP COG mm	weight kg	
UKKS 10	700/500	1,0-1,5/500	II	980	400-1520	700	1000	28	130	265	420	
					400-1520	800				275	440	
					500-1720	700				260	425	
					500-1720	800				280	445	
UKKS 15	1000/500	1,5-1,8/500	II	980	340-1400	700	1000	28	130	275	420	
					340-1400	800				285	430	
					400-1520	700				270	425	
					400-1520	800				280	435	
					500-1720	700				270	430	
					500-1720	800				280	440	
				1050	400-1590	700				260	440	
					400-1590	800				270	450	
					500-1790	700				265	445	
					500-1790	800				275	455	
					1150	400-1690				700	260	460
						400-1690				800	270	470
500-1890	700	255	465									
500-1890	800	265	475									

- 2 hydraulic functions required
- includes hoses and couplings
- pressure gauge as standard

- with protection strip as standard
- supergrip black as standard surface
- other surfaces see page 76
- clamp force options see page 154

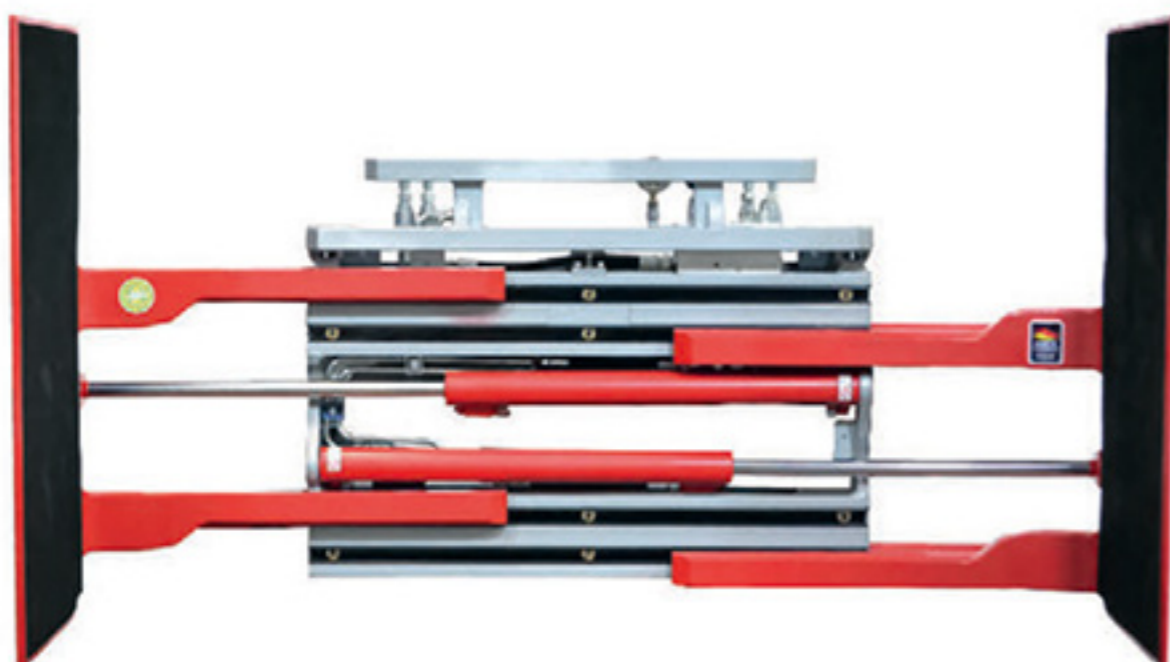



# Appliance clamp, rigid arms

**UKKSE**

integral sideshift, adjustable toe-in

The **appliance clamp UKKSE** features rigid arms. As a difference to model UKKS, the rigid arms are equipped with rubberized aluminium plates. The aluminium plates can be adjusted mechanically vertical and horizontal. As a consequence the arms thickness is increased compared to the appliance clamp UKKS due to the use of exchangeable and adjustable aluminium contact plates.

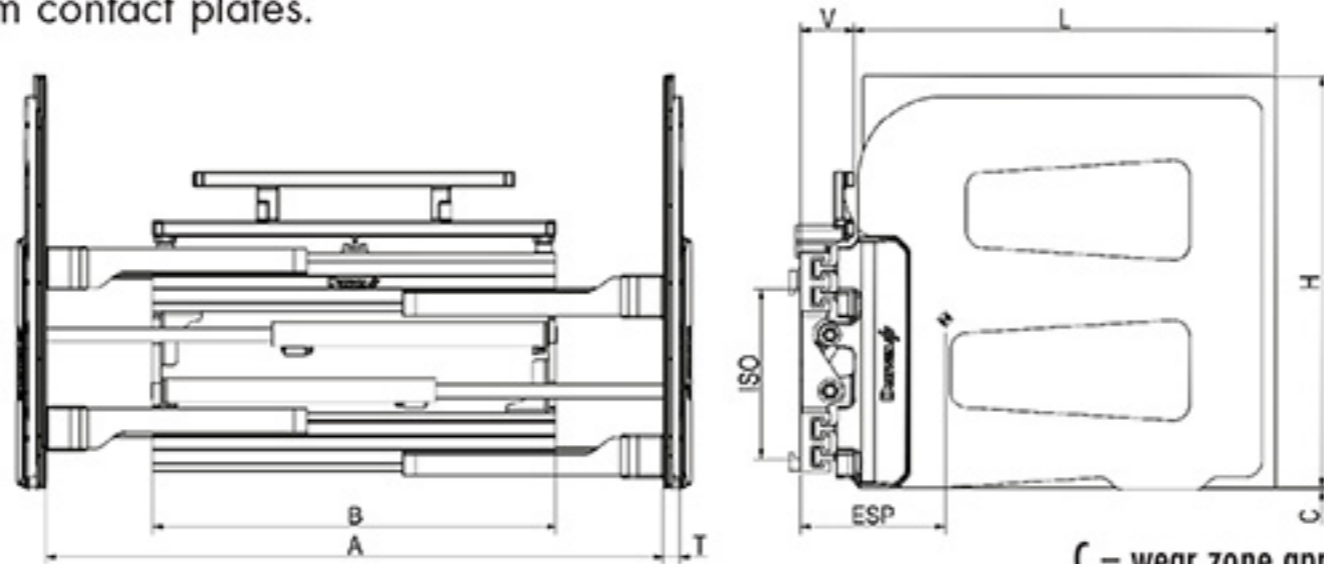

type	capacity kg LC mm	lift truck to LC mm	ISO	B mm	A ITI mm	arm length* L mm	arm height H mm	arm thickness T mm	V LLC mm	ESP COG mm	weight kg
UKKSE 15	1000/500	1,8-2,0/500	II	980	310-1370	920	1000	40	130	345	510
				980	310-1370	1020				355	525
				980	370-1490	920				340	513
				980	370-1490	1020				345	528
				980	470-1690	920				340	515
				980	470-1690	1020				345	530
				1050	370-1560	920				330	523
				1050	370-1560	1020				335	538
				1050	470-1760	920				330	525
				1050	470-1760	1020				335	540
				1150	370-1660	920				325	540
				1150	370-1660	1020				330	555
				1150	470-1860	920				325	545
				1150	470-1860	1020				330	560
UKKSE 25	1300/500	2,0/500	II	980	310-1370	1020	1000	45	130	390	595
				980	370-1490					387	600
				980	470-1690					385	605
				1050	370-1560					380	615
				1050	470-1760					375	620
				1150	370-1660					370	635
				1150	470-1860					367	640
				1250	420-1860					365	660
1350	420-1960	360	670								

- 2 hydraulic functions required
- includes hoses and couplings
- pressure gauge as standard
- with pressure relief valve on the clamp function as standard
- with protection strip as standard
- supergrip black as standard surface

- other surfaces see page 76
- clamp force options see page 154
- other arm dimensions upon request
- constant sideshift upon request

\* Arm length equals the usable length from the arm tip to the load contact on the clamp body, contact plate length - 20 mm

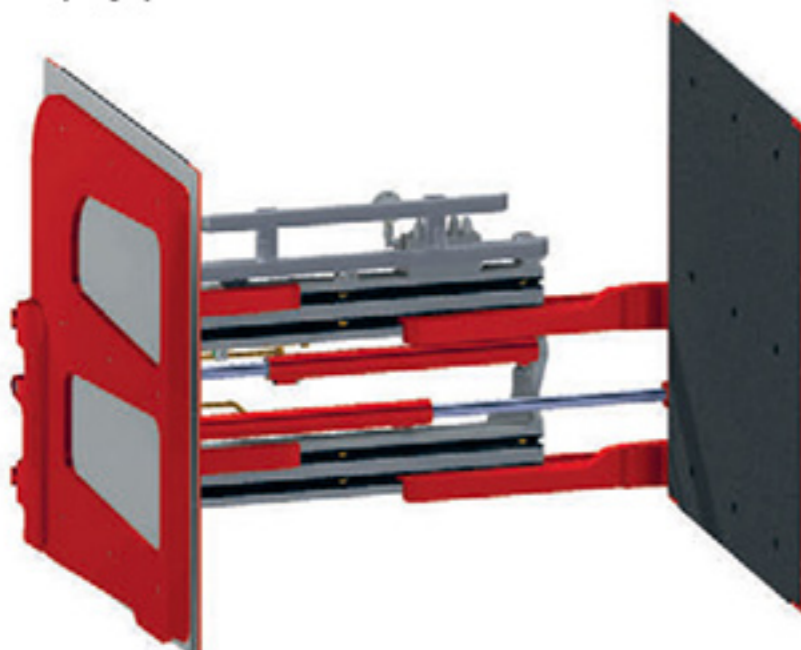

**DURWEN**  
Forklift Attachments

More than 70 years experience



# Appliance clamp

**UKK-PE**  
**UKK-PD**

articulating arms, integral sideshift

The **appliance clamp UKK-PE/PD** with articulating arms is designed for the transport of packaged goods without pallets such as domestic appliances. **Type UKK-PE** is equipped with single articulation on both arms. **Type UKK-PD** has triple articulation on both arms for optimum pressure distribution with split contact plates.

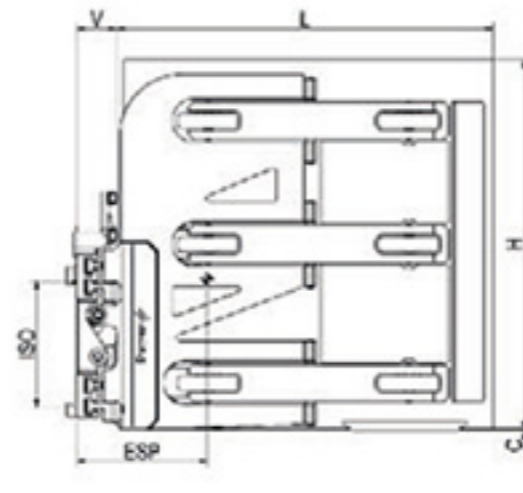
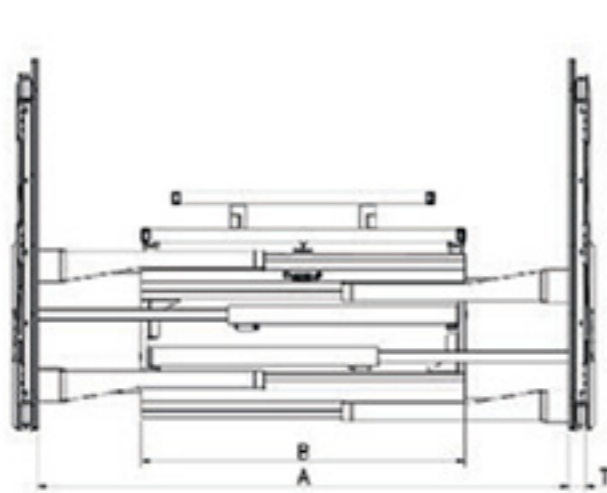

image = PE



C = wear zone approx. 5 mm

type	capacity kg LC mm	lift truck to LC mm	ISO	B mm	A ITI mm	arm length* L mm	arm height H mm	arm thickness T mm	V LLC mm	ESP COG mm	weight kg							
<b>PE = both arms with single articulation</b>																		
UKK 15-PE	1000/600	1,5-1,8/500	II	1050	430-1720	1220	1200	60	130	445	735							
				1150	430-1820	1220				440	750							
				1150	430-1820	1380				465	810							
				1250	430-1920	1220				435	765							
UKK 25-PE	1300/600	2,0-2,5/600	II	1050	430-1720	1220	1200	60	130	440	745							
				1150	430-1820	1220				435	760							
				1150	430-1820	1380				460	820							
				1350	430-2020	1220				430	790							
				1350	430-2020	1380				455	850							
UKK 28-PE	1600/600	2,5-3,0/600	II/III	1350	430-2020	1220	1200	65	140	450	925							
				1350	560-2210	1220				450	930							
				1450	430-2120	1220				440	940							
				1450	560-2310	1220				440	945							
				1450	430-2120	1380				460	995							
				1450	560-2310	1380				460	1000							
				1550	430-2220	1380				455	1010							
				1550	560-2410	1380				455	1015							
UKK 15-PD	1000/600	1,5-1,8/500	II	1050	430-1720	1220	1200	60	130	445	735							
				1150	430-1820	1220				440	750							
				1150	430-1820	1380				465	810							
				1250	430-1920	1220				435	765							
				UKK 25-PD	1300/600	2,0-2,5/600				II	1050	430-1720	1220	1200	60	130	440	745
											1150	430-1820	1220				435	760
											1150	430-1820	1380				460	820
											1350	430-2020	1220				430	790
1350	430-2020	1380	455				850											
UKK 28-PD	1600/600	2,5-3,0/600	II/III	1550	430-2220	1380	1200	65	140	445	880							
				1750	430-2420	1380				450	1040							
1750	560-2610	1380	450	1045														

- 2 hydraulic functions required
- includes hoses and couplings
- pressure gauge as standard
- with pressure relief valve on the clamp function as standard
- with protection strip as standard
- supergrip black as standard surface
- other surfaces see page 76
- clamp force options see page 154

- other arm dimensions upon request
- constant sideshift upon request

\* Arm length equals the usable length from the arm tip to the load contact on the clamp body, contact plate length - 20 mm

**DURWEN**  
Forklift Attachments

More than 70 years experience



## Appliance clamp

articulating arms, integral sideshift

**Appliance clamp UKK-PSD** has one rigid arm for accurate knifing of goods and one arm triple articulating for optimized pressure distribution. **Appliance clamp UKK-PSE** has one arm rigid and one arm with single articulation.

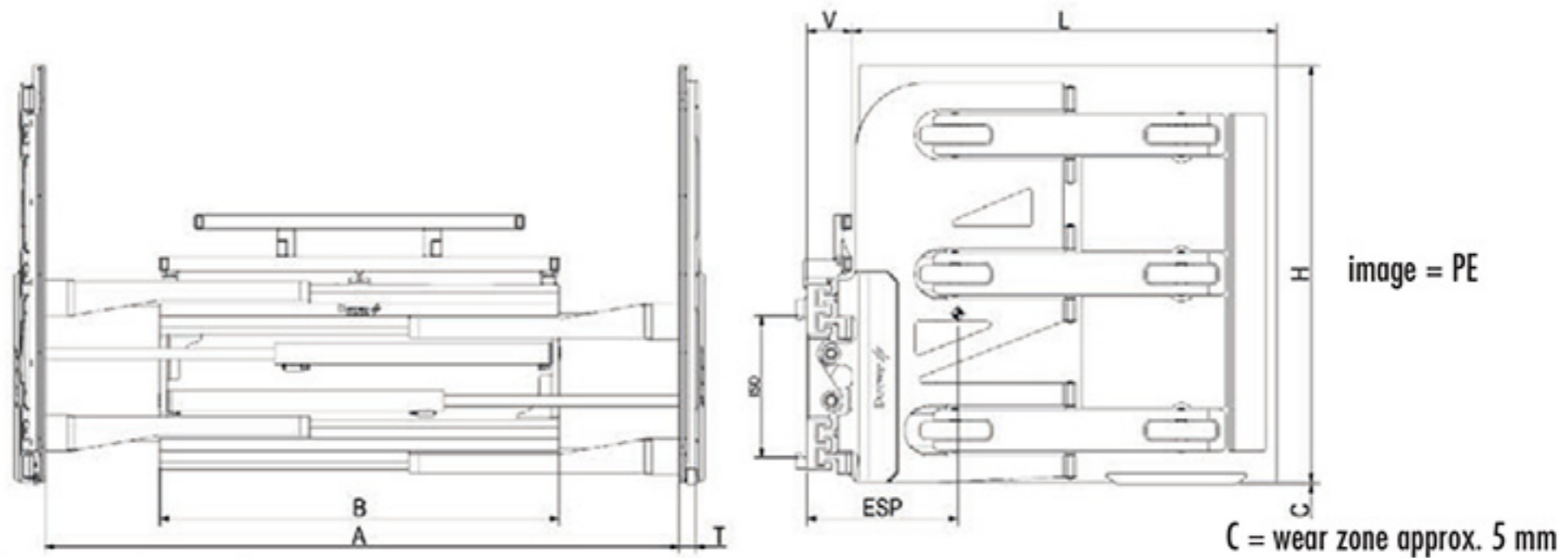

• PSE = 1 arm rigid, 1 arm single articulating

type	capacity kg LC mm	lift truck to LC mm	ISO	B mm	A ITI mm	arm length* L mm	arm height H mm	arm thickness T mm	V LLC mm	ESP COG mm	weight kg
UKK 15 PSE	1000/600	1,5-1,8/500	II	1150	440-1820	1220	1200	60	130	450	760
				1150	440-1820	1380				475	820
UKK 25 PSE	1300/600	2,0-2,5/600	II	1150	440-1820	1220	1200	60	130	445	775
				1150	440-1820	1380				470	835
				1350	440-2020	1220				440	805
				1350	440-2020	1380				465	865

• PSD = 1 arm rigid, 1 arm triple articulating

type	capacity kg LC mm	lift truck to LC mm	ISO	B mm	A ITI mm	arm length* L mm	arm height H mm	arm thickness T mm	V LLC mm	ESP COG mm	weight kg
UKK 15 PSD	1000/600	1,5-1,8/500	II	1150	440-1820	1220	1200	60	130	455	765
				1150	440-1820	1380				480	825
UKK 25 PSD	1300/600	2,0-2,5/600	II	1150	440-1820	1220	1200	60	130	450	780
				1150	440-1820	1380				475	840
				1350	440-2020	1220				445	810

- 2 hydraulic functions required
- includes hoses and couplings
- pressure gauge as standard
- with pressure relief valve on the clamp function as standard
- with protection strip as standard
- supergrip black as standard surface

- other surfaces see page 76
- clamp force options see page 154
- other arm dimensions upon request
- constant sideshift upon request

\* Arm length equals the usable length from the arm tip to the load contact on the clamp body, contact plate length - 20 mm

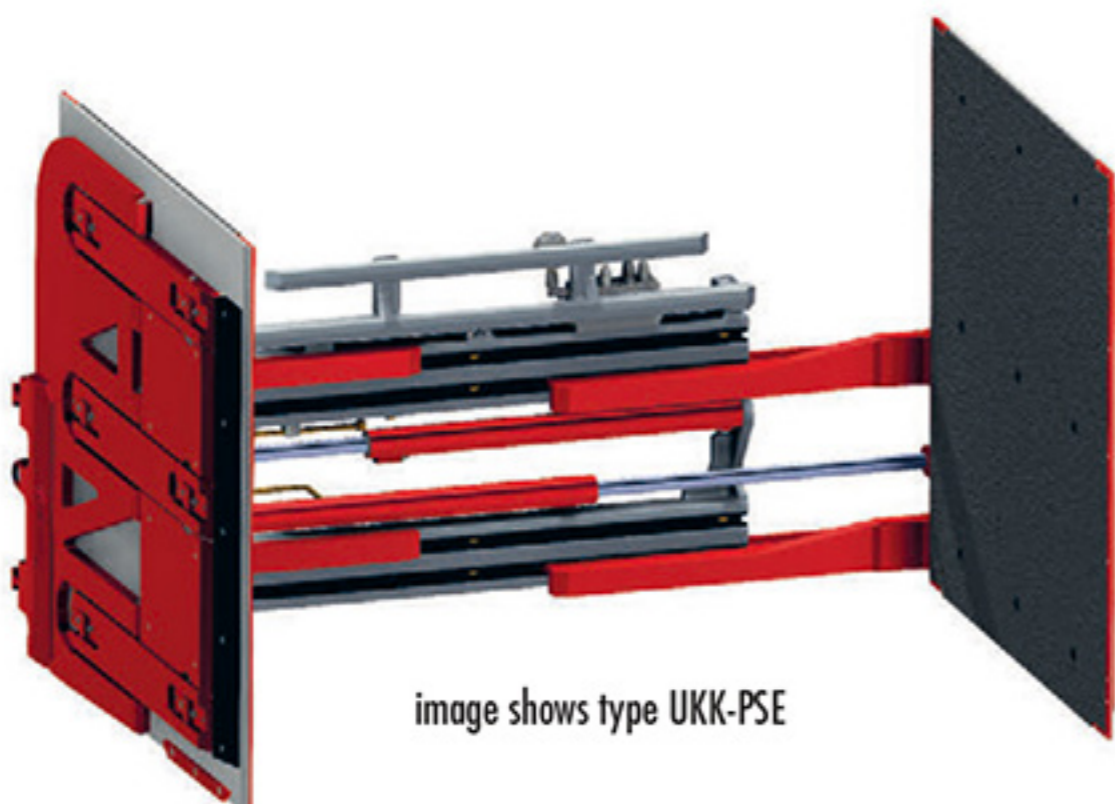

image shows type UKK-PSE

