

iJack-26 (2,600 lbs. Capacity)

Electric Pallet Jack Mobile Weighing Solution

WAREHOUSE ELECTRIC TRUCK SCALES

Call out



Top Quality
Lithium-Ion
Electric
Pallet Jack



Work smarter, not harder, with the iJack-26.

The fully electric pallet jack is built with a lithium-ion battery and lifts, moves, and weighs stock up to 2,600 lbs. As a result, The iJack-26 is an ideal choice for retail or commercial floors.

If your personnel is moving loads over 100 ft with a hand pallet jack, get your hands on this ergonomic truck for a more efficient and safer solution for your material handling needs.

BENEFITS

- Ergonomic handle with reversing switch, horn and dual “butterfly”, Intuitive thumb controls for safe and accurate operation
- Easy exchange battery system functions
- Strong permanent magnet drive motor
- Battery discharge indicator
- Bluetooth technology
- Key switch to limit access to approved personnel
- Forks are 3.2” off the ground, meaning our units will work with many types of pallets

www.mhsignal.com

MHSIGNAL®

iJACK-26

DRIVE AND TRAVEL CONTROLS

- 24-Volt Curtis Travel Control with Permanent Magnet Drive Motor.
- Variable Speed from 0 MPH to 2.8 MPH Empty
- Variable Speed from 0 MPH to 2.5 MPH Loaded

STANDARD SPECIFICATIONS

WEIGHT

- 288 lbs. with Battery

TIRES

- Drive (1) 8.3" X 2.8" Polyurethane
- Load (2) 2.4" X 3.1" Polyurethane

FORKS

- 27" OAW X 45.25" OAL Standard
- Maximum Elevation of 7.5"

CONTROL HEAD

- Travel, lift & lower functions, and creep speed controls
- Easy Operation for Either Hand
- Belly Button Reversing Switch, Dural Butterfly Travel Controls, Wake-Up Buttons, and Key Switch
- Low Mounted Tiller Arm for Comfort and Minimum Steering Effort

HYDRAULICS

- DC Pump and Chrome Plated Cylinder

ELECTRICAL

- Water Resistant Connectors & Wired Harness Supply Power Reliably to Components
- Emergency Power Disconnect
- Covered On-Board Dock for Easy Exchange

BRAKES

- Electromagnetic Brakes

SERVICEABILITY

- Removable Covers & Modular Design of Components
- Two-Piece Drive Wheel
- Easy Exchange HD Battery Delivers up to 3.0 hours of Operation & Charged within 1.5 Hours

EASY EXCHANGE LITHIUM-ION BATTERY

- 24-Volt 20AH Rechargeable
- 110VAC 10A Plug-In External Charger

DIMENSIONS IN INCH

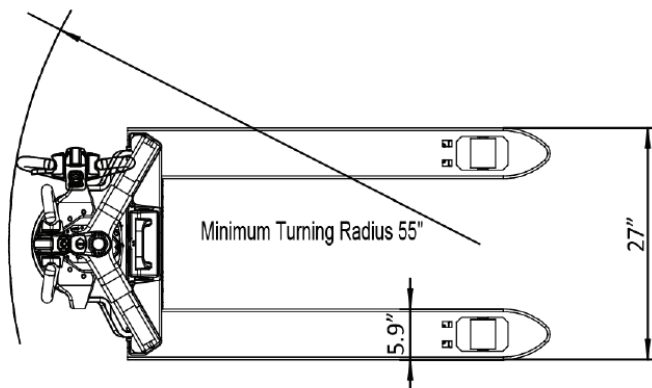
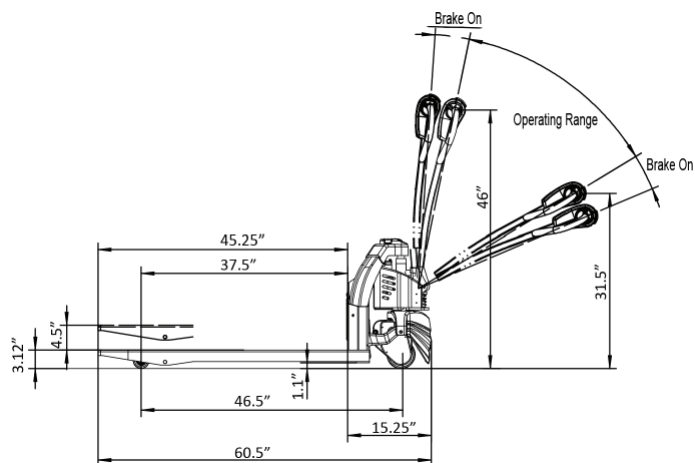

OPTIONS*

- Legal for Trade Version, NTEP
- 48" Load Back Rest
- Bluetooth - or WiFi - Data Transfer
- Additional Set of Li-ion Battery Packs

Distribuidor Autorizado México
Drill en Company

Teléfono: 5555.066.512
mail ventas@mhsignal.com

MHSIGNAL



www.mhsignal.com