

iJack-40 (4,000 lbs. Capacity)

Electric Pallet Jack Mobile Weighing Solution

WAREHOUSE ELECTRIC
TRUCK SCALES

Call out



Top Quality
Lithium-Ion
Electric
Pallet Jack



It's time to find a better way to get the job done.

The revolutionary iJack-40 is a lithium-ion pallet truck designed for maximum productivity and value.

The compact design of the iJack-40 makes a perfect choice for lift-gate delivery fees, store deliveries, while the robust design tackles heavy duty warehousing applications. Throw in the RAVAS scale system and you have the ultimate weigh on the go efficiency.

BENEFITS

- Completely wireless through Bluetooth technology
- Ergonomic-Friendly
- Lithium-Ion Battery Packs
- Easy to Maneuver in Tight Spaces
- Digital Calibration
- Can lift, move, and weigh product up to 4,000 lbs.
- Electromagnetic brakes for excellent stopping power
- Forks are 3.2" off the ground, meaning our units will work with many types of pallets

www.mhsignal.com

MHSIGNAL®

iJACK-40

DRIVE AND TRAVEL CONTROLS

- 48-Volt Curtis Travel Control with Permanent Magnet Drive Motor.
- Variable Speed from 0 MPH to 3.4 MPH Empty
- Variable Speed from 0 MPH to 3.1 MPH Loaded

STANDARD SPECIFICATIONS

WEIGHT

- 390 lbs. with Battery

TIRES

- Drive (1) 8.3" X 2.8" Polyurethane
- Load (2) 2.9" X 3.5" Polyurethane

FORKS

- 27" OAW X 46" OAL Standard
- Maximum Elevation of 7.75"

CONTROL HEAD

- Travel, lift & lower functions, and creep speed controls
- Easy Operation for Either Hand
- Belly Button Reversing Switch, Dural Butterfly Travel Controls, Wake-Up Buttons, and Key Switch
- Low Mounted Tiller Arm for Comfort and Minimum Steering Effort

HYDRAULICS

- DC Pump and Chrome Plated Cylinder

ELECTRICAL

- Water Resistant Connectors & Wired Harness Supply Power Reliably to Components
- Emergency Power Disconnect
- Covered On-Board Dock for Easy Exchange

BRAKES

- Electromagnetic Brakes

SERVICEABILITY

- Removable Covers & Modular Design of Components
- Two-Piece Drive Wheel
- Easy Exchange HD Battery Delivers up to 3.0 Hours of Operation & Charged within 1.5 Hours

DIMENSIONS IN INCH

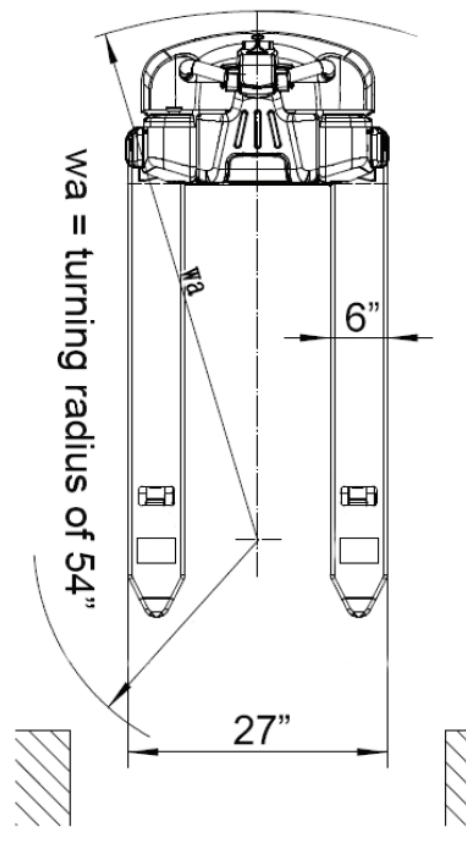
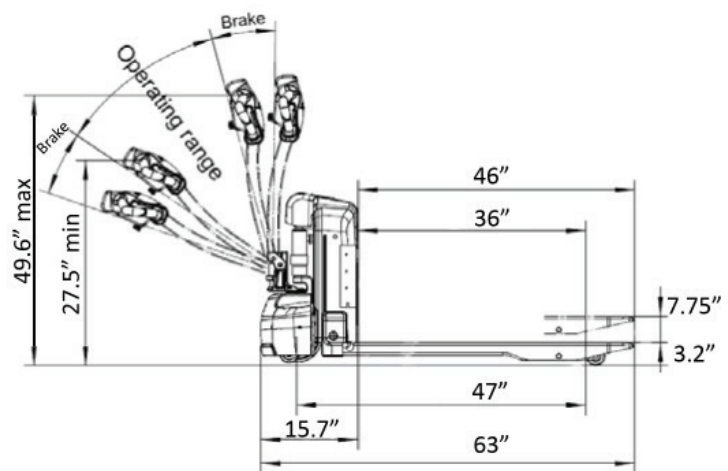

OPTIONS*

- Legal for Trade Version, NTEP
- 48" Load Back Rest
- Bluetooth - or WiFi - Data Transfer
- Additional Set of Li-ion Battery Packs

Distribuidor Autorizado México
Drill en Company

Teléfono: 5555.066.512
mail ventas@mhsignal.com

MHSIGNAL



www.mhsignal.com